



**DYNO 300 CHAIN**

# **ENGINEERING DATA**



# CONTENTS

<b>1. ENGINEERING DATA</b>	<b>1</b>
ENERGY CONSUMPTION COMPARISON.....	1
Dyno Plastic Chain Versus Steel Chain.....	1
Details Needed.....	1
<b>2. DESIGN GUIDELINES</b>	<b>2</b>
Take Ups For Conventional Drive Conveyors.....	2
How To Ensure Good Sprocket And Chain Lite.....	2
Soft Starts.....	2
Conveyor Frame Requirements.....	2
Chordal Action.....	3
Wearstrips.....	3
Recommended Wearstrip fastening.....	3
Return Rollers.....	4
Some Common Conveyor Design Problems.....	4
Catenary Design Recommendations.....	5
Selected illustrations depicting typical catenary design recommendations.....	5
<b>3. ELEVATING/PUSHER CONVEYORS</b>	<b>6</b>
“Z” Conveyor Design Recommendations.....	6
Pusher Conveyors.....	6
Differences In Conveyor Structure.....	6
<b>4. FORMULAS</b>	<b>8</b>
Calculating Belt Pull For Horizontal Conveyors.....	8
Formula 1. (F) - Determining Total Friction Factor.....	8
Formula 2. (CP) - Total Chain Pull of Conveyor at Drive Sprockets.....	8
Calculating Adjusted Chain Pull.....	8
Formula 3. (AP) - Adjusted Chain Pull.....	8
Elevating Conveyors.....	8
Formula 4. (CPI) Chain Pull on incline in kg.....	8
Formula 5. (API) Adjusted Chain Pull in kg.....	8
Curve Conveyors.....	8
Formula 6. (CPB) - Chain Pull on Bends in kg.....	8
Formula 7. (APB) - Adjusted Chain Pull in kg.....	8
Total Pull Per Chain.....	8
Formula 8. (TP) - Total Pull Per Chain.....	8
Formula 9. (w) - Total Running Load on Shaft.....	8
Formula 10. (D) - Shaft Deflection.....	8
Formula 12. (Wa) - Watts at Drive Shaft.....	8
Formula 13. (To) - Torque.....	8



<b>5. TABLES</b>	<b>9</b>
Symbols Used in Calculations. ....	9
Table 1B ..... Maximum Recommended Load and Length for Rollers on Roller Bed Conveyors. ....	9
Table 1A ..... (W) Chain Weight in Kilograms per Metre (Max) + Attachments if any .....	9
Table 2A ..... (Fw) Co-efficient of Start-Up Friction Between Wearstrip and Chain. ....	10
Table 2B ..... (Fp) Co-efficient of Running Friction Between Container and Chain. ....	10
Table 3 ..... (SF) Service Factor .....	10
Table 4 ..... Maximum Working Loads .....	10
Table 5 ..... (T) Temperature Factor .....	11
Table 6 ..... (S) Speed Factor .....	11
Table 7 ..... Average Power Factors For Curves .....	11
Table 8 ..... Shaft Data .....	11

# 1. ENGINEERING DATA

## ENERGY CONSUMPTION COMPARISON

### Dyno Plastic Chain Versus Steel Chain

Plastic's lighter weight and lower coefficient of friction result in significant energy savings,

This chart measures the energy used by both a plastic chain and a steel chain.

Additional savings can be obtained by using smaller motors and fighter gear reducers that are more energy efficient than the larger units required on steel chains. Details Needed.

#### EXAMPLE: 15 METRE LONG CONVEYOR

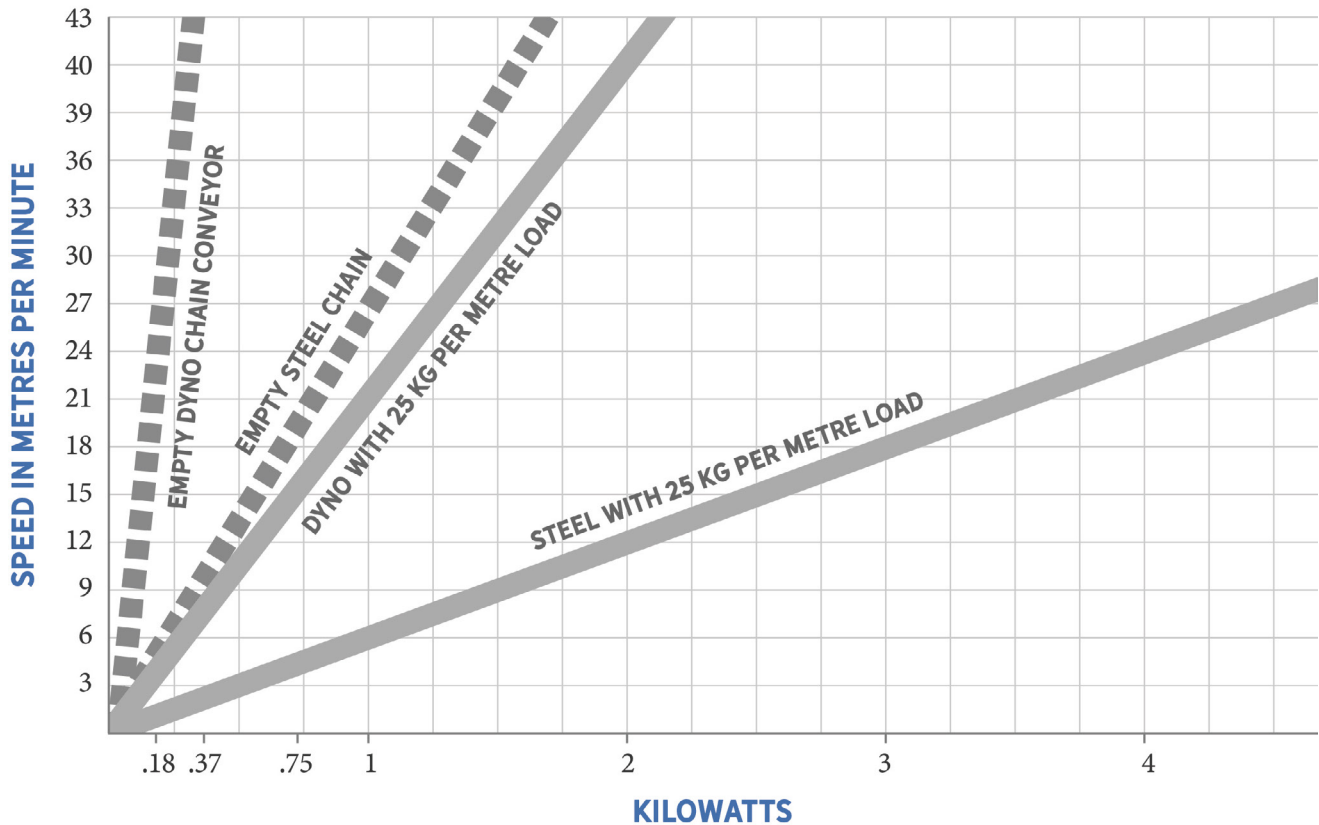

**COST PER YEAR**

@ 40 hours/week	1 kWh	2 kWh	3 kWh	4 kWh
@ 10c kWh	\$208	\$416	\$624	\$832

### Details Needed

1. CONVEYOR LENGTH, centre to centre \_\_\_\_\_
2. CONVEYOR WIDTH, number of chains \_\_\_\_\_
3. VERTICAL LIFT \_\_\_\_\_
4. CHAIN SPEED, metres/minute \_\_\_\_\_
5. DUTY CYCLE, % of 24-hour day \_\_\_\_\_
6. PRODUCT MASS ON CHAIN kg/metre \_\_\_\_\_
7. % CHAIN "BACKED UP" \_\_\_\_\_
8. ACCUMULATING (note one) \_\_\_\_\_
9. SHAFT LENGTH UNSUPPORTED \_\_\_\_\_
10. TEMPERATURE. AVERAGE (note two) \_\_\_\_\_
11. MAXIMUM \_\_\_\_\_
12. MINIMUM \_\_\_\_\_

13. STARTS PER HOUR \_\_\_\_\_
14. LOADED STARTS. Yes/No \_\_\_\_\_
15. SOFT START MOTOR. Yes/No \_\_\_\_\_
16. CONVEYOR TYPE DRIVE, Normal/Pusher \_\_\_\_\_
17. SHAFT MATERIAL, Hollow/Solid \_\_\_\_\_
18. WHAT IS A PRODUCT? \_\_\_\_\_
19. WEAR STRIP MATERIAL \_\_\_\_\_
20. WHAT CHEMICALS ARE PRESENT? \_\_\_\_\_

**NOTE ONE:**

A chain is "backed up" when the product is held stationary while the chain continues to run.

**NOTE TWO:**

This figure must represent the average temperature when the chain is actually running.

## 2. DESIGN GUIDELINES

### Take Ups For Conventional Drive Conveyors

**Screw ease Style of Take Ups** should be used only as required for ease of assembly and for adjustment of return catenary to recommended sag.

**NOTE ONE:** Care should be taken to maintain the shaft alignment.

**NOTE TWO:** Overtightening of chain will only reduce sprocket and chain life by increasing the load and increased shaft deflection.

**Gravity Style Take Ups** are recommended:

1. For conveyors over 15 metres long.
2. For conveyors less than 2 metres long at speeds over 3 metres/minute.
3. Conveyors exposed to large temperature extremes.
4. Chain speeds over 40 metres/minute and length over 10 metres with light loads.
5. Chain speeds over 15 metres/minute with frequent starts with loads over 30 kg per metre.

### How To Ensure Good Sprocket And Chain Life

A design checklist to ensure good performance for all positive driven conveyors:

1. Moderate catenary sag is required to allow some space for chain growth that will occur from load, thermal expansion and wear.
2. Largest sprocket size acceptable.
3. Sell-tensioning on high-speed, pusher and/or large temperature change conveyors.
4. Correct alignment and transition of chain from carry way to sprockets.
5. No interference from frame or drip pan with chain at drive sprocket catenary.
6. Well-locked sprockets.
7. Limited shaft deflection.
8. True alignment of idle and drive shafts.
9. Sufficient carry way support for the applied load.
10. Ensure Idler Sprockets are firmly located but able to rotate independently.

### Soft Starts

Soft starts are recommended for all drives designed for chain speed exceeding 15 metres/minute and when chain pull exceeds 50% of recommended rating or pull.

Soft starts should also be applied for drives applied to conveyors with curves and speeds exceeding 10 metres/minute.

### Conveyor Frame Requirements

Dimensional data is furnished below for the design and construction of suitable new frames or the adapting of old frames. Side guides should have 3 to 5 mm clearance per chain.

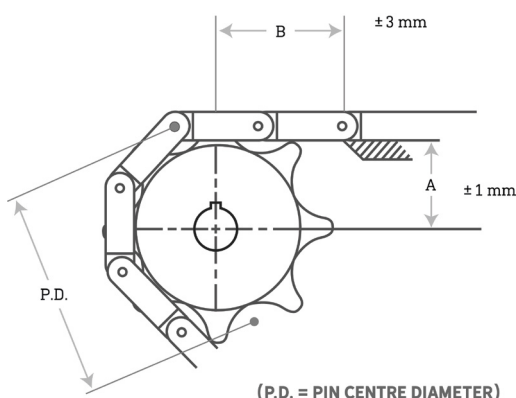

**FRAME DIMENSIONS (mm)**

Sprocket	PD	A	B
6 Tooth Cast Aluminium	152	63	82
8 Tooth Cast Aluminium	200	86	94
8 Tooth Polyethylene	200.6	86	94
14 Tooth Cast Aluminium	346	159	121

## Chordal Action

The rise and fall of each pitch of chain as it engages a sprocket is termed "chordal action" and causes repeated chain speed variations (pulsations). As illustrated by the graph, chordal action and speed variation decreases as the number of teeth in the sprockets is increased. Where smooth operation is essential, use as many teeth as possible in the sprockets.

### VARIATIONS IN CHAIN SPEED DUE TO CHORDAL ACTION

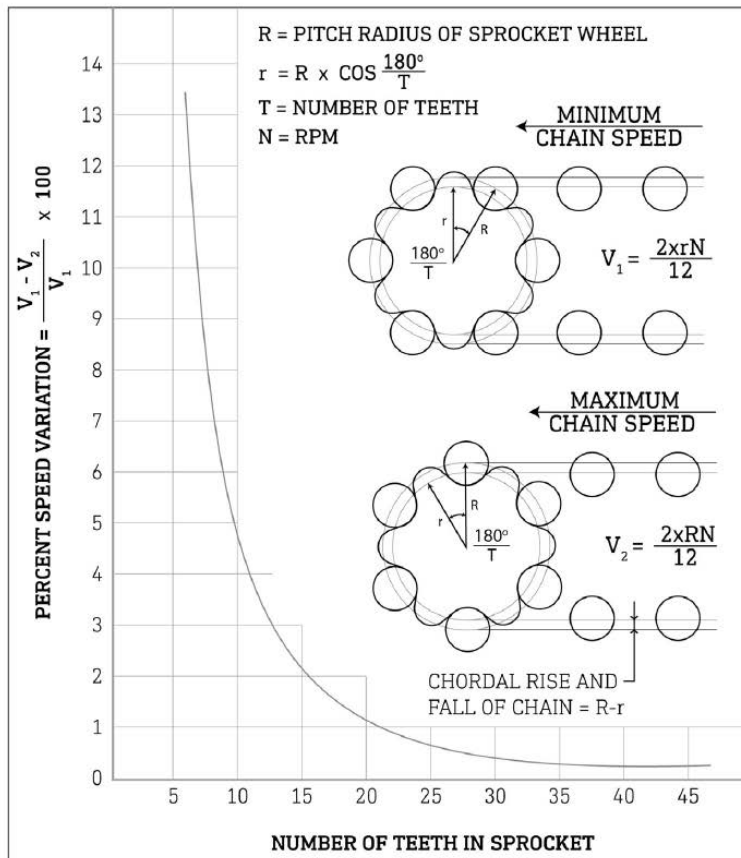

*The variation between minimum and maximum chain speed due to chordal action is 13% for a 6 tooth sprocket, 8% for an 8 tooth sprocket, and 2.5% for a 14 tooth sprocket.*

## Wearstrips

S.S. wearstrips are normally the most satisfactory. Other wearstrips can be added for the following reasons:

1. To increase the useful life of the conveyor ways.
2. To keep friction and power requirements low.

U.H.M.W.P.E. is the most commonly added wearstrip but it will not necessarily increase the useful life of Chain. In an abrasive situation, the softest material will often absorb abrasive particles and wear the harder material quicker.

On any chain conveyor high loadings and speed as well as grit or fibrous products may reduce the life of sprockets end chain. Wear from grit may be reduced by the use of the largest sprocket feasible for your application and running chain as slow as possible.

## Recommended Wearstrip fastening

6 mm thick wearstrips are fastened in short lengths with plastic bolts and nuts at the leading end only, to provide clearance for elongation caused by moisture and temperature.

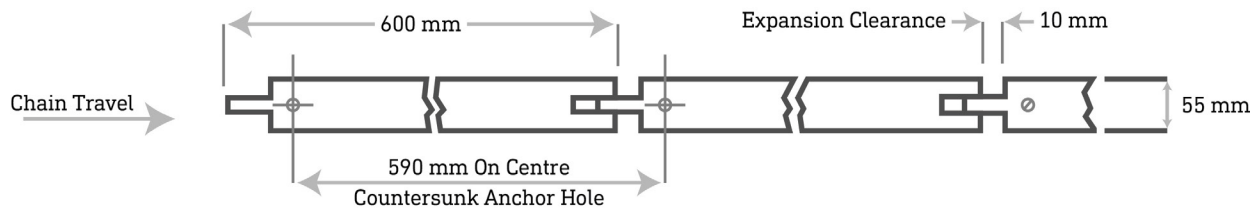

## Return Rollers

Recommended maximum lengths of return rollers if used:

- Use 50 mm plastic pipe for conveyors up to 600 mm wide.
- Use 60 mm plastic pipe for conveyors up to 900 mm wide.

Roller carry ways may be used with Dyno 300 Chain at moderate speeds to reduce friction.

Distance between support rollers should be a maximum of half the length of the goods to be carried and at no more than 250 mm centres.

## Some Common Conveyor Design Problems

### Full return does not allow for chain growth

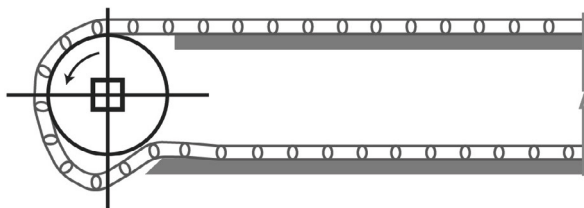

### Drive shaft low relative to carry way

Places load high on tooth form. Results are similar if shaft deflection is excessive.

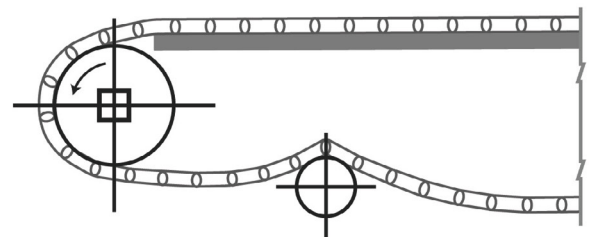

### Drip pan or guard too close

May eliminate back tension.

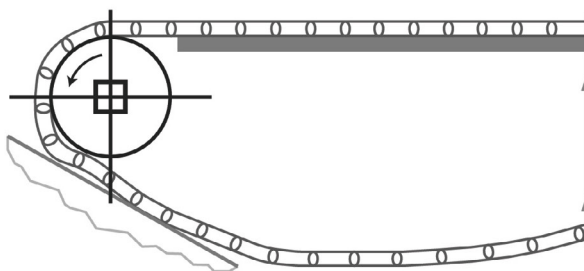

### Carry way extended too close to sprocket centre line

Places load high on tooth form.

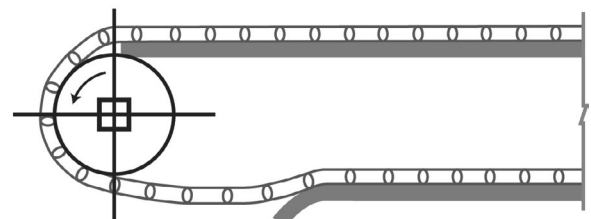

### Roller too close

May eliminate back tension.

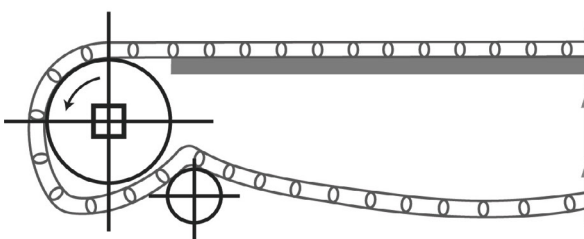

### Never leave sharp edge on carry way

Chamfer or curl down to ensure smooth entry from idle sprocket,

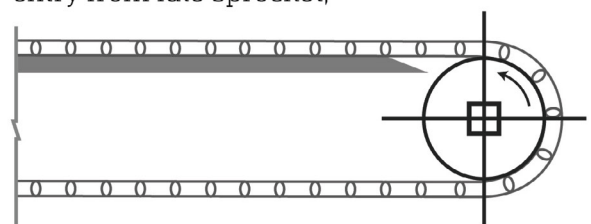

# Catenary Design Recommendations

Selected illustrations depicting typical catenary design recommendations.

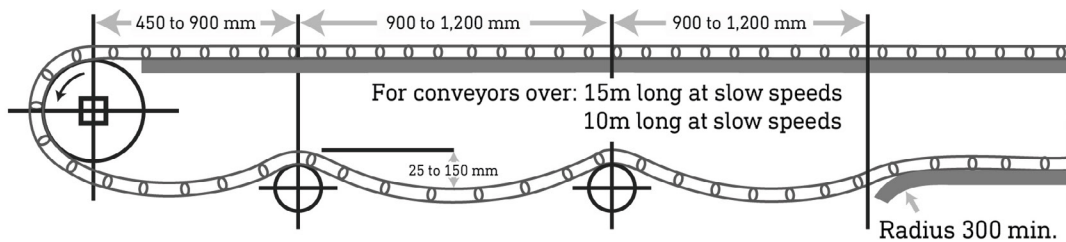
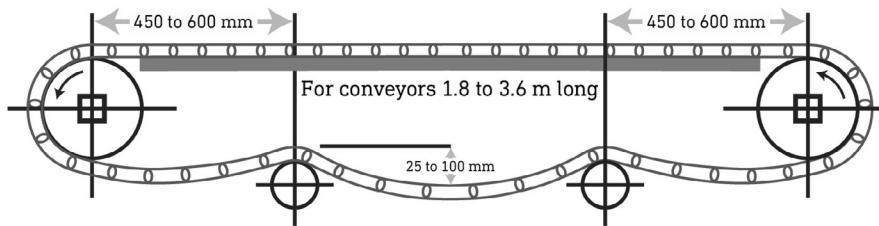
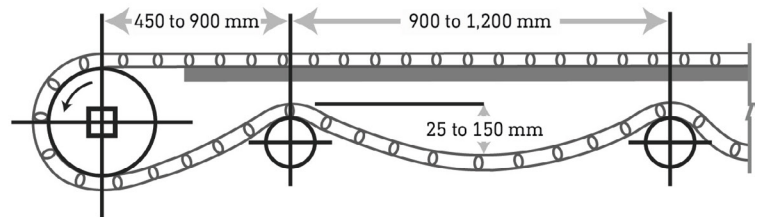
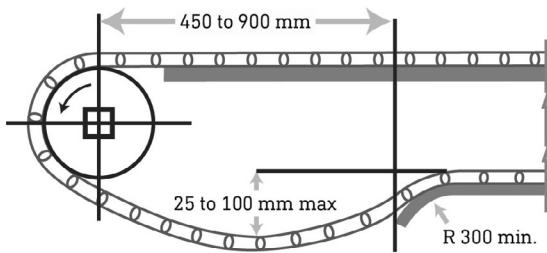
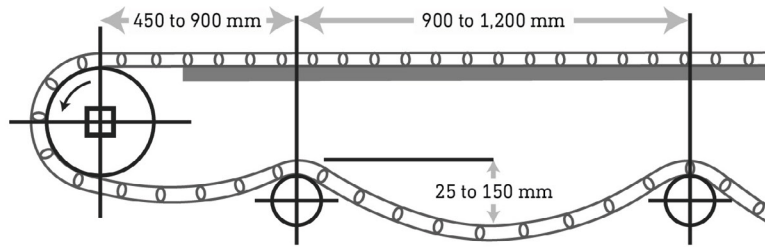

1. For conveyors with large temperature extremes.
2. For conveyors with over 30 kg per metre of load and running over 15 m per minute with frequent starts.

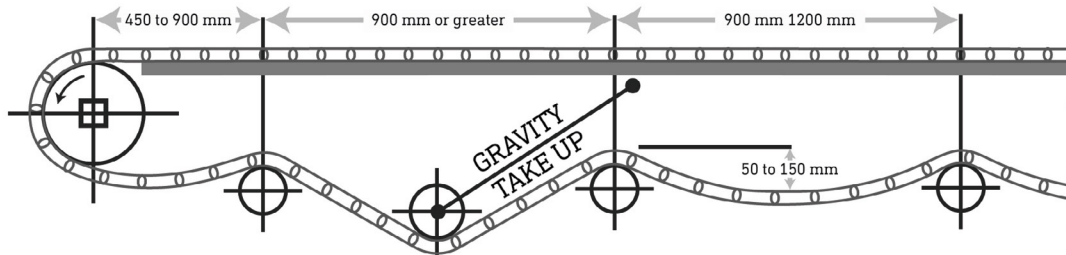

SLIDER OR ROLLER RETURN IS AT DESIGNER'S OPTION  
Slider return is recommended for higher speeds.

## 3. ELEVATING/PUSHER CONVEYORS

### “Z” Conveyor Design Recommendations

#### COMMON CONDITIONS:

- C. Use carry way wearstrip up to 30°. Use sprockets over 30°.
- D. Hold down shoe radius is recommended to be as large as the application will allow (up to 900 mm radius) to minimize wear. The minimum radius is 150 mm.
- E. Minimum 75 mm diameter roller or shoe.

#### WITH SHOE RETURN

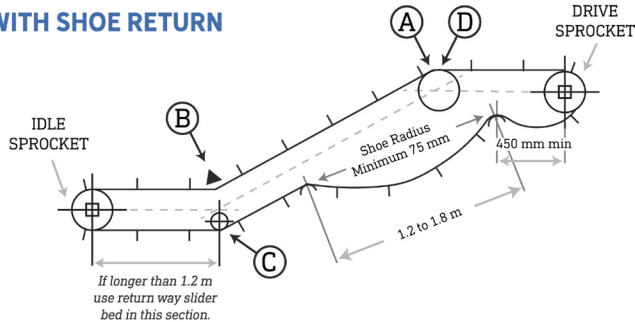

#### WITH SLIDER BED RETURN AND SCREW TAKE-UP

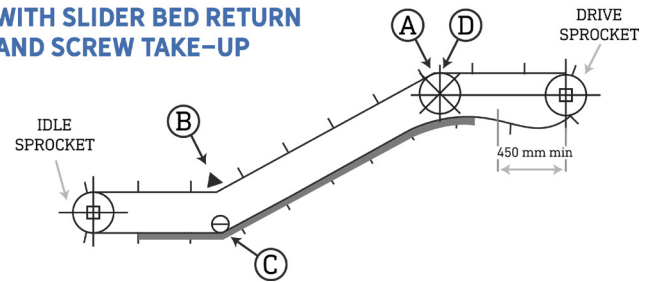

## Pusher Conveyors

For chain users who desire to push their conveyor, for example:

- **Bi-directional Conveyors** with a single end drive.
- **Elevators** that require motors to be at ground level.

To avoid buckling (tenting) of the pushed chain it is necessary to add more tension in these pusher conveyors than the chain pull (BP).

$$\begin{aligned} \text{Required Tension} &= \text{BP} \times 1.2 \\ \text{or for elevators} &= \text{BPI} \times 1.2 \\ \text{or for curves} &= \text{BPC} \times 1.2 \end{aligned}$$

- **Corrected BP** for shaft deflection and sprocket loading calculations are:
 
$$= \text{BP} \times 2.2$$
- or for elevators:
 
$$= \text{BPI} \times 2.2$$
- or for curves:
 
$$= \text{BPC} \times 2.2$$

**Note: H.P. and torque are not affected by tension except effects of higher loadings on bearings which are not included in these calculations.**

## Differences In Conveyor Structure

1. A take up must be used to adjust the catenary.
2. Some portion of the return way must be unsupported; either distance between two rollers on roller return or the removed section of return way should leave the chain unsupported for 2.4 to 3 metres of length,
3. Catenary sag in chain should be adjusted to 15 mm minimum, 40 mm maximum. Actual dimension to be determined in the field.

**Important:** Setting a minimum amount of sag is important since screw take up can be tightened to almost infinite tension and doing so will cause excess shaft deflection, sprocket loading and decreased chain and bearing life,

4. Since a pusher conveyor in comparison to conventionally driven conveyors is excessively tensioned a larger shaft deflection of 5 mm is tolerable.
5. Regarding shaft deflection and sprocket spacing, both end shafts should be considered drive shafts.

## PUSH-PULL DESIGNS BI-DIRECTIONAL DRIVE ARRANGEMENT

**1.2 to 15 m**

For loads under 12 kg per metre.

**2.4 to 3 m**

For loads under 12 kg per metre.

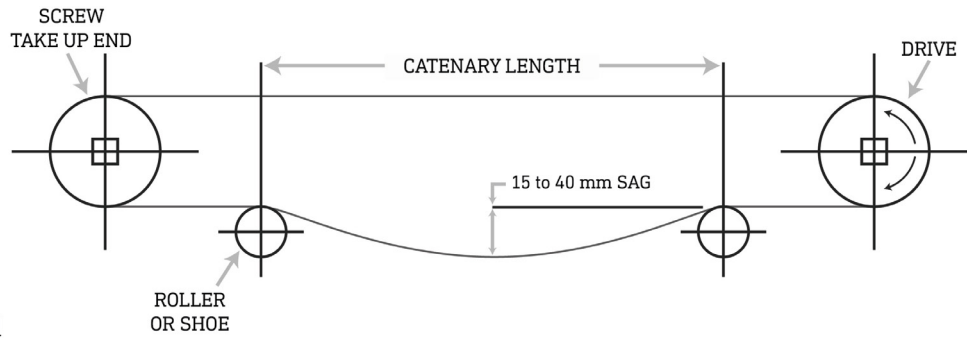

Both of these Push-Pull designs are suitable for:

- a. Speeds up to 3 metres/minute.
- b. Speeds between 3 and 8 metres/minute with soft start motors.
- c. Chain pulls of less than 40% of max. Chain strength.

## FOR WIDE SYSTEMS REQUIRING CENTRE BEARING SUPPORT

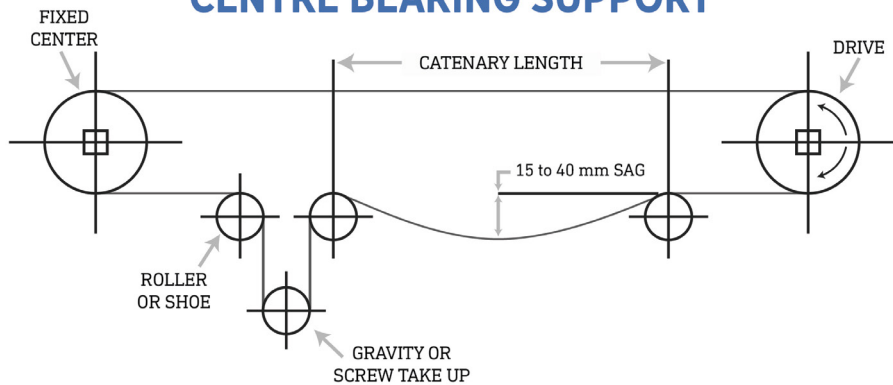

## PULL-PULL DESIGNS BI-DIRECTIONAL DRIVE ARRANGEMENT

Use two motors with slip clutch, or one motor-driven shaft with roller chain and sprockets, with slave driving second shaft.

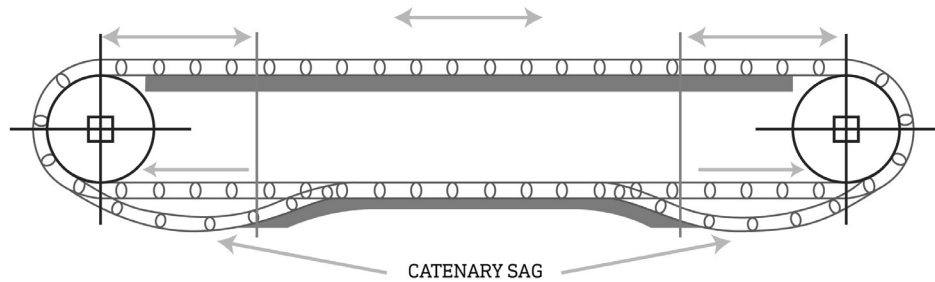

## CENTRE-DRIVE PULL-PULL DESIGN

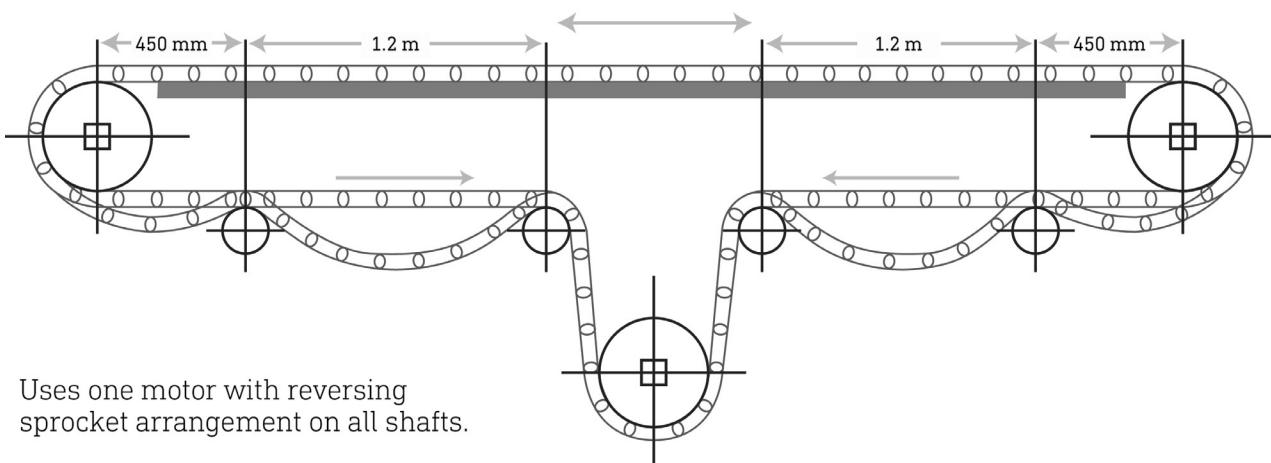

Uses one motor with reversing sprocket arrangement on all shafts.

# 4. FORMULAS

## Calculating Belt Pull For Horizontal Conveyors

Formula 1. (F)

**DETERMINING TOTAL FRICTION FACTOR**

$$F = Fw + (\text{Percent of accumulation of Product})$$

For chain running under accumulated containers:

Obtain (Fw) from **Table 2A**.

Obtain (Fp) from **Table 2B**.

For bulk products or containers that are not backed up on moving conveyor:

Obtain (Fw) from **Table 2A**.

Ignore (Fp) since it does not apply.

Formula 2. (CP)

**TOTAL CHAIN PULL OF CONVEYOR AT DRIVE SPROCKETS**

$$CP = [M + (2W \times N)] \times L \times F \times SF$$

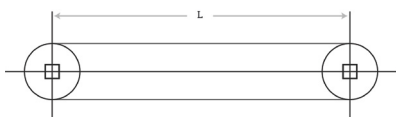

## Calculating Adjusted Chain Pull

The actual (CP) Chain Pull is modified by temperature and speed factors obtained from Formulas 5. and 6. These tables take into account sprocket selection and chain materials.

Formula 3. (AP)

**ADJUSTED CHAIN PULL**

$$AP = \frac{CP}{T \times S}$$

## Elevating Conveyors

Should be designed the same as conventional conveyors with the following two exceptions:

1. Additional work is required to lift the product.
2. Design considerations for bends in the elevator.

**SAMPLE PROBLEM FOR ELEVATING CONVEYORS**

Additional Symbols used:

- H = Vertical rise of conveyor.
- L<sub>1</sub> = Length of incline.
- L<sub>2</sub> = Length of goose neck (if any)
- L<sub>3</sub> = Length of lower horizontal section (if any)

Note: All measured in metres.

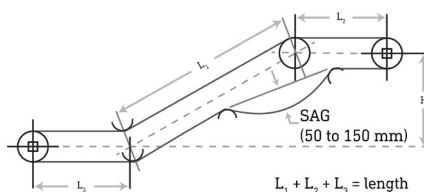

Formula 4. (CPI)

**CHAIN PULL ON INCLINE IN KG**

$$CPI = CP + (M \times H)$$

Formula 5. (API)

**ADJUSTED CHAIN PULL IN KG**

$$AP = \frac{CPI}{T \times S}$$

## Curve Conveyors

Should be designed the same as conventional conveyors with the following exceptions:

1. Straight lead-in and lead-out of bends. Should be minimum of 450 mm to sprockets.
2. Minimum side radius of 750 mm.
3. Guides may be needed above the side lug to hold chain down.
4. Extra drive is required — see formula.

Formula 6. (CPB)

**CHAIN PULL ON BENDS IN KG**

$$CPB = CP \times PF$$

Formula 7. (APB)

**ADJUSTED CHAIN PULL IN KG**

$$APB = \frac{CPB}{T \times S}$$

## Total Pull Per Chain

Formula 8. (TP)

**TOTAL PULL PER CHAIN**

$$APB = \frac{AP \text{ or } API \text{ or } APB}{N}$$

From **TP** determine if design is within chain load rating see **Table 4**. If not, re-consider design. Possibilities are to add extra chains, reduce length per drive unit or change chain material.

Formula 9. (w)

**TOTAL RUNNING LOAD ON SHAFT**

$$w = \left[ \frac{CP + \text{Shaft Weight per Metre}}{SF} \right] \times B$$

Reference: **Shaft Weight** kg/metre see **Table 8**.

Formula 10. (D)

**SHAFT DEFLECTION**

$$D = \frac{5}{384} \times \frac{w \times Ls^3}{E \times I}$$

**Note:** Shaft Deflection of greater than 2.5 mm is not recommended.

Formula 12. (Wa)

**WATTS AT DRIVE SHAFT**

$$Wa = \frac{TP \times N \times 9.81 \times V}{60}$$

Formula 13. (To)

**TORQUE**

$$To = \frac{TP \times N \times PD}{2}$$

# 5. TABLES

## Symbols Used in Calculations

Symbols Used in Calculations	Location	Measurement
CP = Chain pull at Drive Sprocket	Formula 2	kg
TP = Total Pull Per Chain	Formula 8	kg
AP = Chain Pull Adjusted for Speed and Temperature	Formula 3	kg
W = Chain Weight	Table 1A	kg/m
M = Product Weight	-	kg/m
L = Length of Conveyor	-	metres
B = Width of Conveyor	-	metres
F = Fw and Fp	Formula 1	-
Fw = Co-efficient of Friction (Chain to Conveyor)	Table 2A	-
Fp = Co-efficient of Friction (Chain to Container)	Table 2B	-
SF = Service Factor	Table 3	-
S = Speed Fedor	Table 6	-
T = Temperature Factor	Table 5	-
N = Number of Chains	-	-
D = Shaft Deflection Under Load	Formula 10	Milimetres
Ls = Shaft Length Unsupported	-	Milimetres
E = Modulus of Elasticity of Shaft Material	Table 8	kg/mm <sup>2</sup>
I = Moment of Inertia of Shaft Cross Section	Table 8	mm <sup>4</sup>
w = Total Running Load on Shaft	Formula 9	kg
v = Chain Speed	-	metres/minute
PD = Sprocket Pitch Diameter	See Page 2	Milimetres
HP = Horsepower	Formula 11	-
Wa = Watts	Formula 12	Watts
To = Torque	Formula 13	kg - mm x 9.81 = Newton - mm
CPI = Chain Pull on Incline	Formula 4	kg
API = Adjusted Chain Pull on Inclines	Formula 5	kg
CPB = Chain Pull on Bends	Formula 6	kg
APB = Adjusted Chain Pull on Bends	Formula 7	kg
PF = Average Power Factor on Bends	Table 7	-

**Table 1B**

### Maximum Recommended Load and Length for Rollers on Roller Bed Conveyors

	Max Load in kg per Roller	Maximum Length in mm For Rollers		
		For unsupported accumulation rollers between EP chains	For rollers supported separate from chain between EP chains or Rollers carrying products but not turning on EP chain	For rollers with through shafts
Plastic Rollers 42 mm O. D.	15	300	600	500
Plastic Rollers 48 mm O. D.	25	400	750	600
Plastic Rollers 60 mm O. D.	30	400	900	750
Steel or Stainless Steel 50.8 mm O.D. x 1.6 mm Wall Tube	35	400	1,200	900

**Table 1A**

### (W) Chain Weight in Kilograms per Metre (Max) + Attachments if any

	Acetal and Acetal x L	Nylon	Nylon Super Tough	Nylon High Load	H.T.P.	P.E.	P.P.	P.P.G.F.
Short Pin Chain	1.23	1.1	1.11	1.25	1.1	.95	.92	1.13
Extended Pin Chain	1.49	1.35	1.37	1.52	1.36	1.21	1.19	1.4

For roller bed conveyors with rollers between chain add roller weight/metre.

		PR Plain Rollers (add to weight of E.P. Chain)	TR Through Shaft Rollers (add to weight of S.P. Chain)
Plastic Rollers	Base Weight	+ weight per 100 mm of roller length	+ weight per 100 mm of roller length
42 mm O.D.	.45	.58	1.33
48 mm O.D.	.45	.75	1.49
60 mm O.D.	.64	.88	1.63
Steel or Stainless Steel 50.8 mm O.D. x 1.6 mm Wall Tube	.56	2.6	3.35

Add base weight + PR per 100 mm or TR per 100 mm to give kg/metre with roller on every pin. If rollers are not on every pin divide weight accordingly.

## Table 2A

### (Fw) Co-efficient of Start-Up Friction Between Wearstrip and Chain

Wearstrip	Chain Material							
	Polypropylene				Polyethylene		Acetal Nylon & H.T.P.	
	Non-Abrasive		Abrasive		Non-Abrasive		Non-Abrasive	
	Wet	Dry	Wet	Dry	Wet	Dry	Wet	Dry
UHMWPE	.12	.17	-	-	-	-	.08	.10
Cold Rolled Finish Stainless or Carbon Steel	.20	.30	.25	.35	.15	.25	.15	.25
		**		**		**		**

\* Abrasive is defined as light grit, dirt or fibre.  
 \*\* Not recommended over 15 metres/minute.

Friction is sometimes unpredictable. Take into consideration if rust, grit or heavy loads are involved.

## Table 2B

### (Fp) Co-efficient of Running Friction Between Container and Chain

Container Material	Chain Material					
	Polypropylene		Polyethylene		Acetal Nylon & H.T.p.	
	Wet	Dry	Wet	Dry	Wet	Dry
Glass	.10	.12	.12	.15	.08	.10
Metal	.15	.20	.12	.15	.12	.15
Plastic	.10	.12	.15	.15	.10	.15
Cardboard	-	.30	-	.25	-	.25

At speeds greater than 15 metres/minutes on conveyors that are started with backed up lines, soft start motors should be considered. If chain is fully supported on rollers or load is carried on rollers Fw or Fp will become 0.1 for bushes or 0.03 for bearings.

## Table 3

### (SF) Service Factor

Starts under no load, with load applied gradually		1.0
Frequent starts under load (more than once per hour)	Add .2	_____
At speed greater than 3 metres/minute	Add .2	_____
At speed greater than 30 metres/minute	Add .2	_____
Elevators	Add .2	_____
Pusher Conveyers	Add .4	_____
24 Hour Operation	Add .2	_____
Curves in Conveyor	Add .4	_____
	TOTAL	_____

## Table 4

### Maximum Working Loads

Material	Kg
Acetal	300
Nylon	200
H.T.P.	175
Polypropylene	75
Polyethylene	50

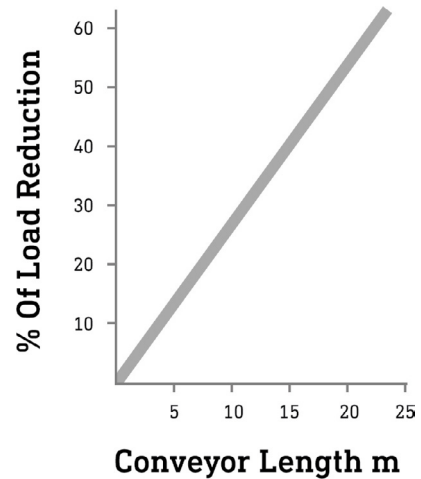

Accumulated chain stretch over the length of a conveyor can cause uneven running. To reduce this, maximum load must be reduced as length increases.

For further details on load ratings see material specifications or consult Dyno N.Z.

Other materials are available for problem situations.

## Table 5

### (T) Temperature Factor

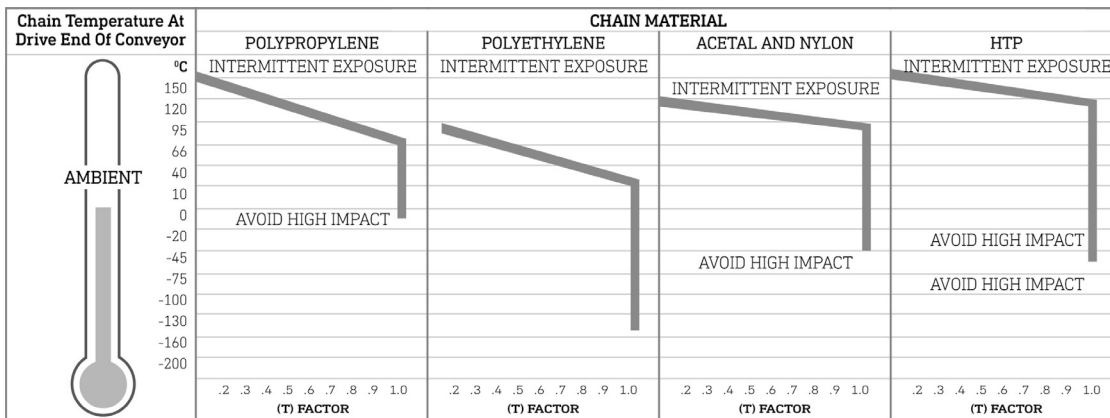

Approximate thermal expansion .09 mm per metre per °C.

## Table 6

### (S) Speed Factor

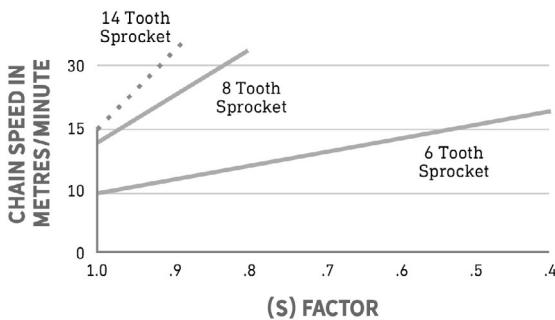

Note: At higher speeds, lubrication between chain and carry way is recommended.

Lubrication must be used above the following speeds:

- Polypropylene :** 20 to 30 metres/minute.
- Polyethylene :** 15 to 20 metres/minute.
- Acetal, Nylon and H.T.P :** 30 to 35 metres/minute.

## Table 7

### Average Power Factors For Curves

Degree of Curve	Power Factor (PF)
45°	1.25
60°	1.50
90°	1.60
120°	1.75
135°	2.00
180°	2.50

The power factors are average based upon various loading conditions. They should be applied to calculating chain pull requirements for running in the curve(s).

## Table 8

### Shaft Data

Shaft Diameter		Moment of Inertia: I	Weight
Inches	mm	mm <sup>4</sup>	kg/m
1.00	25.4	20,400	3.9
1.25	31.75	49,876	6.2
1.4375	36.51	87,845	6.4
1.50	38.1	103,457	8.9
1.9375	49.2	289,472	16
2.5	53.5	798,472	24.8
1.50 sq.	38.1	175,600	11.4
2.50 sq.	63.5	1,355,000	31.7

**E = 21,100 kg/mm<sup>2</sup> for Carbon Steel.**  
**E = 19,700 kg/mm<sup>2</sup> for Stainless Sleet.**

