



A to B, seamlessly.



Sprocket Catalogue '17



It's how businesses get along

At Dyno we make the world of
business go round.

Up and down.

And side to side.

Our conveyors make moving meat,
veges, fruit, packages, gravel, and even luge sleds simple and
efficient.

We can customise to meet your needs
and all our designs are proprietary.

It all sounds new and high-tech, and it is.
But in reality we're an inter-generational
Kiwi company which has been designing and building conveyors
for over two decades now.

All that experience, and our knowledge
of the industries we work with,
is part of a total approach that includes supplying parts, and
maintenance by trained engineers.



DYNO Conveyors warranties equipment supplied free from defective materials and workmanship for a period of 5 years, subject to satisfactory care and maintenance and being used according to original specifications.

CONTENT

- Design considerations 4
- Part number (descriptions)5-6
- Ordering details 7
- Sprockets
 - Sprockets 8-9
 - Adaptors 10
 - Pulleys 11
 - Driven Rollers 12-13

DESIGN CONSIDERATIONS

Details Required:

- Type of product being conveyed
- Length of product
- Width of product
- Height of product
- Weight of product
- Speed required
- Environmental conditions

Rollers

A minimum of three rollers are required under the load at all times, products with uneven bases require more.

Ideal roller length is - load width + 50mm. This is a critical minimum with some types of plastic crates, but is of lesser importance with flat bottomed cartons.

Pallets usually flex under load causing only 1/3 of the rollers to carry the load, always allow for this.

Tapered rollers guarantee correct movement on bends.

Precision bearing rollers run smoothly at higher speeds for long periods but can have a greater resistance for manual movement.

Advantages of Plastic Rollers

- Light weight
- Noise dampening
- Resistance to corrosion
- Cleanliness

Temperature range of all our standard plastics is 5°C to 40°C, although they can be used down to -20°C with lowered impact resistance, or up to 60°C with reduced load.

Dynopipe is extra special high impact resistant PVC.

Shafts

Spring loaded shafts are the simplest design, giving quick and easy assembly and maintenance.

Male and female threaded shafts give higher load capacity and reduced vibration as they are secured direct to the conveyor frame. Female threads have the advantage of very simple assembly.

Spring loaded shafts are standard on most rollers.
Female threads are most common on driven rollers.
Large diameter rollers often have a fixed shaft.

Many other options are available to special order.

Remember – Gravity works for free

Roller Bearings

e.g. $\underbrace{50}_1 \underbrace{7}_2 \underbrace{SS}_3 - \underbrace{12H}_4 \underbrace{(Z14DF)}_5$

1. Tube Outside Diameter in nearest mm
2. Bearing type
 - 0 = Bush
 - 1 = Thermoplastic race, carbon steel balls
 - 2 = Thermoplastic race, stainless steel balls
 - 3 = Steel (unground)
 - 4 = Steel (unground), thermoplastic housing
 - 5 = Precision bearing, zinc plated steel housing and bush
 - 6 = Precision bearing, zinc plated steel housing, thermoplastic bush
 - 7 = Precision bearing, thermoplastic housing and bush. Press fit
 - 8 = Precision bearing, thermoplastic housing and bush. Swage fit
 - 9 = Fixed, for example = drums
3. Bearing details
 - A = Antistatic
 - B = Blind
 - C = Caged balls
 - G = Greased (extra)
 - HD = Heavy duty
 - M = Machined
 - SE = Sealed (extra)
 - SS = Stainless steel precision bearing
 - T = Includes locater for tapered elements
4. Shaft size + detail
 - H = Hexagonal across flats dimension
 - Q = Ø10mm with 8mm across flats
5. Extras
 - Z = Chain sprocket
 - ZB = Toothed belt sprocket
 - 14 = Number of teeth
 - S = Single
 - D = Double
 - F = Fixed
 - L = Loose

ROLLER BEARINGS

e.g. **50 7 SS – 12H (Z14DF) / D2.8 – SS – SP 447OBL / T**

1
2
3
4
5
6
7
8
9
10

1. Tube Outside Diameter in nearest mm.
2. Bearing type, (as per Roller Bearing part number description).
3. Bearing details, (as per Roller Bearing part number description).
4. Shaft size + detail, (as per Roller Bearing part number description). Standard Shaft: 15mm out each end
5. Extras, (as per Roller Bearing part number description).
6. Tube material + (wall thickness when ordering non-standard wall thickness rollers)
 - AL = Aluminium.
 - D = Dynopipe.
 - G = Galvanised steel.
 - R = Rubber coated.
 - P = Plastic.
 - N = Stainless steel.
 - B = Black
7. Shaft material
 - AL = Aluminium.
 - MS = Mild steel.
 - SS = Stainless steel.
 - ZP = Mild steel zinc plated

8. Type of shaft
 - DL = Cross drilled.
 - F = Fixed.
 - FL = Flats.
 - FT = Female threads.
 - MT = Male threads.
 - SP = Sprung.
 - P = Loose

9. Length of roller
 - IF = Inside frame.
 - OBL = Over bearing length.

10. Extras
 - T = Taper.
 - GR = Grooves + spacing from over bearing, e.g.
 - SL = Non standard shaft length and details.

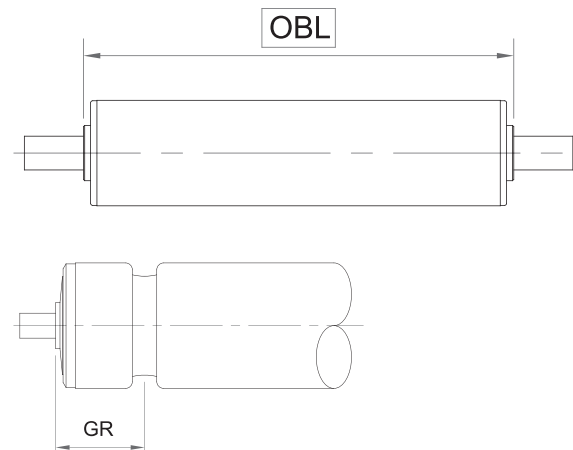

Measured from outside of bearing to centre of groove

Tube Outside Diameter	
Ø20	
Ø25	
Ø32	
Ø38	
Ø42	
Ø48	
Ø50	
Ø51	
Ø60	
Ø76	
Ø89	
Ø114	
Other	

Tube Material	
Plastic	
Dynopipe	
Galv. steel	
Stainless steel	

Tube Wall Thickness	
Standard	
Heavy duty	
Other	

Shaft Size	
Ø6	
Ø8	
8mm Hex	
Ø9.5	
Ø10	
10Q (Al)	
Ø11	
11mm Hex	
Ø12	
Ø12.7	
Ø15	
Ø16	
16mm Hex	
Ø17	
Ø19	
Ø20	
Ø25	
Other	

Shaft Material	
Mild steel	
Stainless steel	
Aluminium	
Other	

Cross Drilled	
One end	
Both ends	
Hole size	
Distance from end	

Flats	
One end	
Both ends	
Length of flats	mm
Across flats	mm

Threads	
Female threads	
Male threads	
One end	
Both ends	
Thread size	
Thread depth	mm

Bearing Type	
Bushed	
Plastic race, carbon steel balls	
Plastic race, S/S balls	
Steel (unground)	
Steel (precision)	
Plastic housing (precision)	
Stainless steel (precision)	

Shaft Details	
Loose	
Spring loaded	
Fixed	

Bearing Extras	
Antistatic	
Blind	
Greased	
Sealed	

Extras	
Tapers	
Details	
Grooves	
Position No. 1 (C)	
Position No. 2 (D)	
Sprockets	
Single	
Double	
Fixed	
Loose	
Rubber coating	
Other	

Roller Length (mm)	
Inside frame (IF)	
Over bearing length (OBL) (A)	
Non standard shaft length (B)	

Standard Spring Loaded shaft lengths

- Ø6mm = OBL + 25mm
- Ø8 – Ø15mm = OBL + 30mm
- Ø16mm plus = OBL + 40mm

Quantity Required

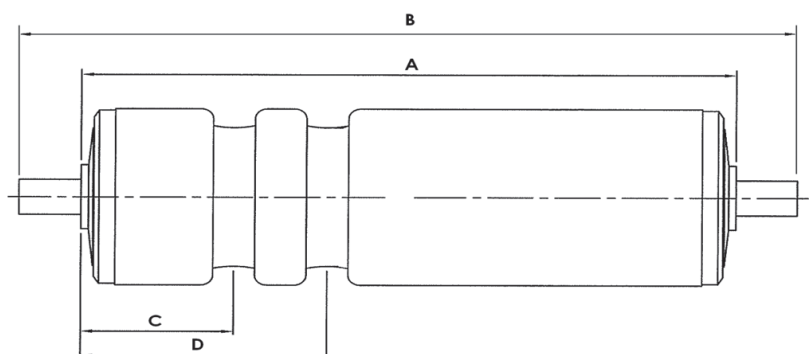

SP6 / SP10 Lightweight Roller Drive

- White Acetal.
- Effective bush bearing.
- ½" pitch (takes B.S. chain).
- 15 tooth.
- Fits range of end caps.
- Bore size
 - SP6 (6.5mm)
 - SP10 (10mm)

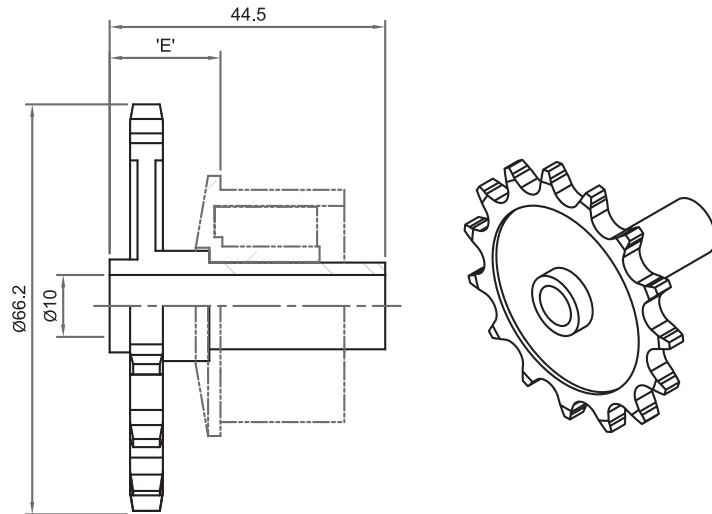

Z11S Sprocket

- Black nylon body.
- 6202 precision bearing (Inner).
- Black nylon bush bearing (Outer).
- 11 tooth.
- ½" pitch.
- Fixed drive (Z11SF).
- Loose (Z11SL).
- Fits range of tube sizes with adaptors (see drive ring details).
- Standard 12mm bore (other sizes special order).
- Options;
 - Stainless steel precision bearing
 - Blind bush on outer

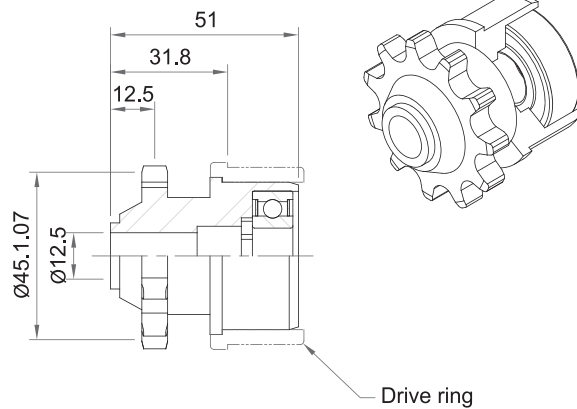

SPROCKETS

Z14S Single Row

- Black nylon body.
- Black polypropylene labyrinth & reducer bush.
- 14 tooth.
- ½" pitch.
- Fixed drive (Z14SF).
- Loose (Z14SL).
- Fits range of tube sizes with adaptors.
- Standard 12mm bore. (other sizes special order)
- Can be fitted with any 507 series labyrinth for other shaft sizes.
- Option; Stainless steel precision bearings

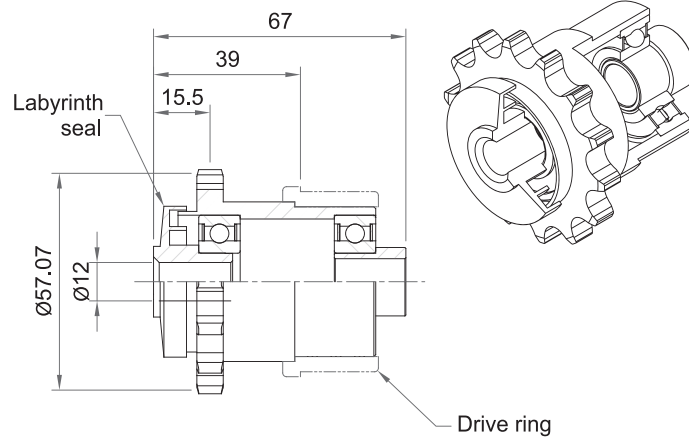

Z14D Double Row

- Black nylon or zinc plated steel body*.
- Black polypropylene labyrinth & reducer bush.
- 14 tooth.
- ½" pitch.
- Fixed drive (Z14DF).
- Loose (Z14DL).
- Fits range of tube sizes with adaptors.
- Standard 12mm bore.
- Can be fitted with any 507 series labyrinth for other shaft sizes.
- Option; Stainless steel precision bearings
- Zinc Plated Steel Type: ZM14D

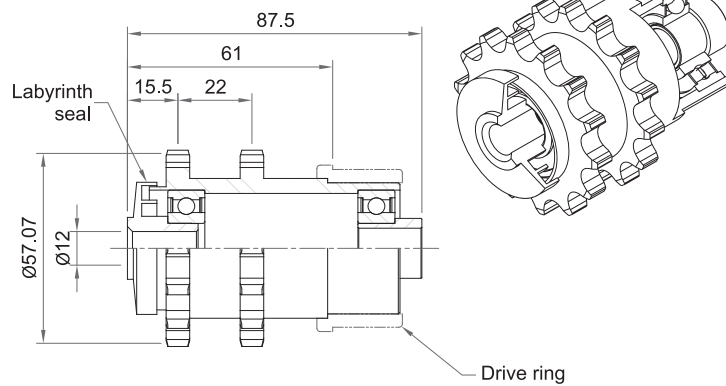

ZMW14D Double Row (weld in)

- Zinc plated steel body
- 14 tooth
- ½" pitch
- Fits 50 x 1.5mm Steel Tube
- Standard bore 12mm (other sizes special order)

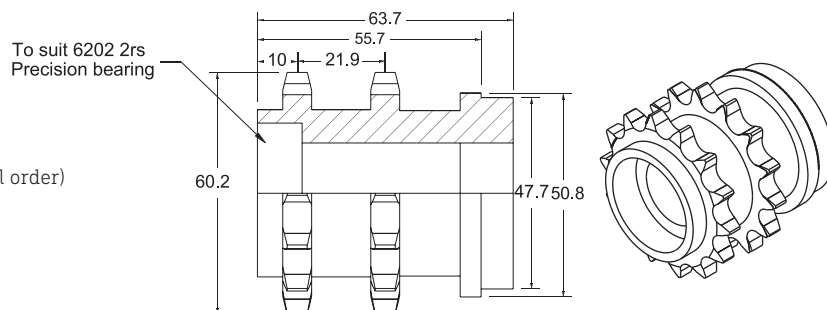

AD60 Adaptor

- Black nylon.
- Suits;
 - 60 x 2.3 tube - Galv. steel
 - S/S (sch. 10)

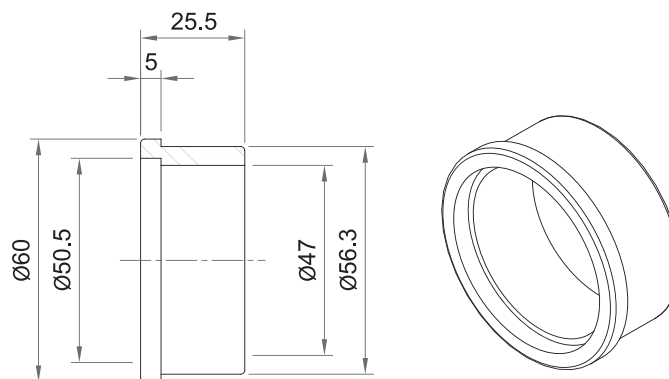

AD89 Adaptor

- Black polycarbonate.
- Suits;
 - 89 x 3.2 tube - Galv. steel (80 NB light)
 - S/S (80 NB sch. 10)
 - Aluminium

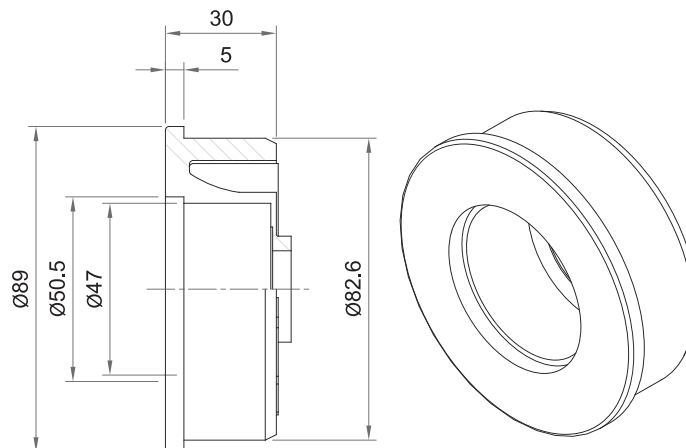

DR-F/L Drive Ring Details

- Fixed (F) black nylon.
- Loose (L) black acetal. (For Accumulation)
- Suits;
 - 50 x 2.8 Dynopipe
 - 50 x 1.6 tube - Galv. steel
 - Aluminium
 - 50.8 x 1.85 - Galv. steel
 - 50.8 x 2 - S/S
 - 60mm adaptors
 - 89mm adaptors

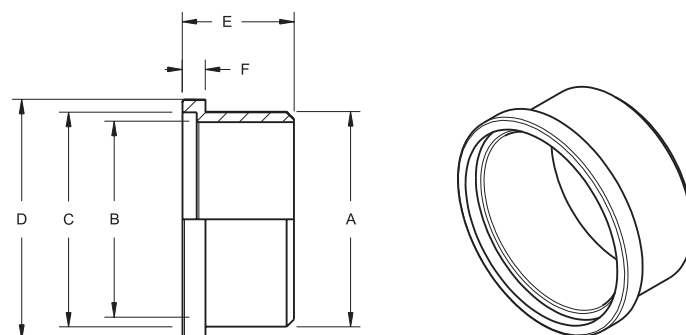

	Fixed 2.8	Loose 2.8	Fixed 1.5	Loose 1.5
A	44.7mm	44.6mm	47.25mm	47.2mm
B	39.3mm	40.6mm	39.4mm	40.6mm
C	42.5mm	44.6mm	42.6mm	44.6mm
D	50mm	49.7mm	50mm	50mm
E	25.2mm	25.2mm	25.2mm	25.2mm
F	5mm	5mm	5mm	5mm

PULLEYS

TB20 Tooth Belt Pulley

- Black nylon body.
- Black polypropylene labyrinth & reducer bush.
- 20 tooth.
- 8mm pitch.
- Fixed drive (TB20F).
- Loose (TB20L).
- Fits range of tube sizes with adaptor.
- Standard 12mm bore.
- Can be fitted with any 507 series labyrinth for other shaft sizes.
- Option; Stainless steel precision bearing

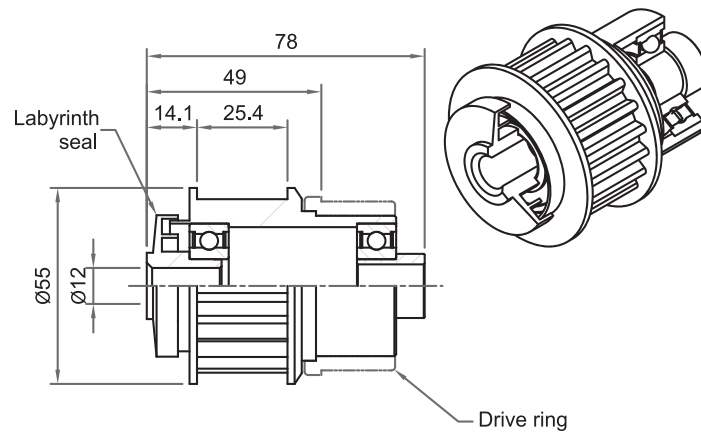

MV50P-9G

- Black nylon body.
- 9 Vee's
- 6002 Bearing
- Standard 12mm bore (other sizes special order)
- Fits 50 x 1.5 Galv Tube
- Option: SS or Steel(ZP)

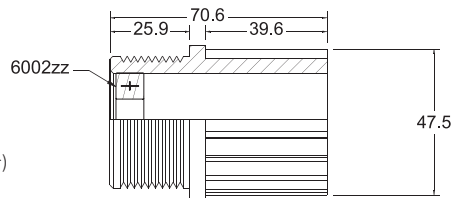

MV89S-23G

- All steel body
- 23 Vee's
- Load Rating 300kg
- Fits 25mm Shaft
- Fits 89 x 3.2mm Galv and SS Tube
- Option: SS

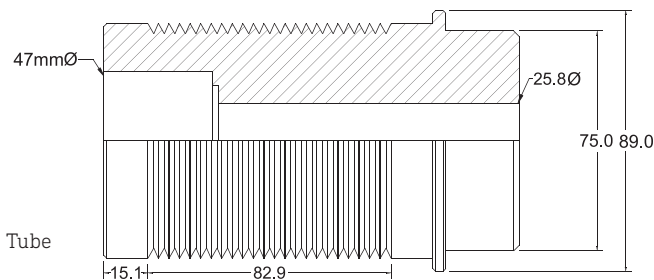

DRIVEN ROLLERS

Driven Roller Tube Diameter - 50, 60, & 89mm

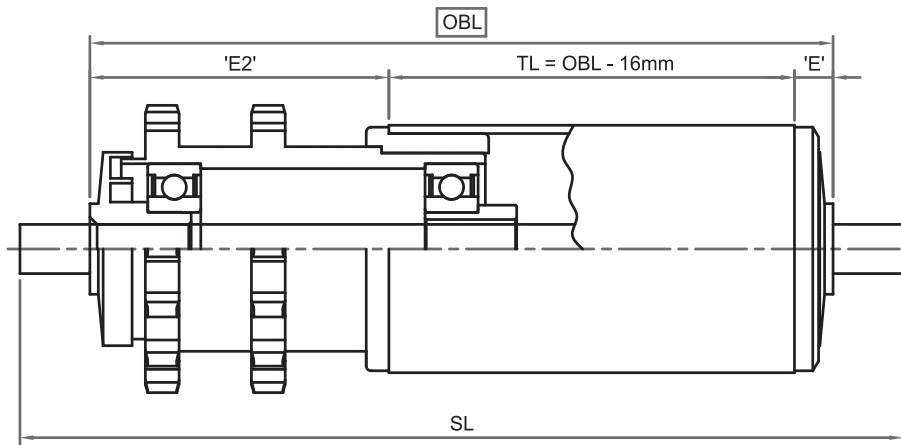

	'E'			'E2'
	Tube Size			Ø50, Ø60, & Ø89mm
	Ø50mm	Ø60mm	Ø89mm	
Z11S	8	7.5	9.5	32
Z14S	8	7.5	9.5	39
Z14D	8	7.5	9.5	61
TB20	8	7.5	9.5	49.5
Bearing Type	507	607	897	
Accumulating Pressure	4 - 7%	2 - 5%	1 - 3%	
Double accumulating pressure for double ended drive				

- Standard Ø12, & Ø16mm shaft.
- Max. product weight 200kg.
- Max. total product weight on conveyor 2 tonne.
- Max. length of conveyor – 50 rollers or 15m each direction from drive, whichever is greater.
- Speed;
 - Chain sprocket 30 m/min (without excessive noise).
 - Toothed belt 90 m/min.

Driven Roller (Cont.)

Loose (Accumulating roller)

- Load Rating kg (Minimum applies).

Roller Length (mm)	Tube Material				Shaft			
	Dynopipe	Aluminium	Galv.		Spring Loaded		Fixed	
	Ø50mm	Ø50mm	Ø50mm	Ø60mm	Ø12mm	Ø14mm	Ø12mm	Ø14mm
200	30	45	50	50	50	50	50	50
300	30	45	50	50	45	50	50	50
400	28	40	50	50	40	50	50	50
500	16	30	50	50	36	50	50	50
600	12	25	50	50	28	45	50	50
700	5	20	50	50	23	43	50	50
800	3	10	50	50	19	37	50	50
900	2	5	50	50	17	32	50	50
1000	1	2	50	50	15	28	50	50
1100			50	50	13	25	50	50
1200			50	50	12	23	50	50
1300			45	50	11	21	50	50
1400			35	45	10	20	50	50
1500			20	35	9	18	50	50

- Max. static load 40kg.
- Z9S - Max. static load 20kg.
- Ø60 & Ø89 tubes – Max. 50kg
- Ø10mm shaft – Max. 20kg up to 500 long.
- Ø8mm shaft – Max. 10kg up to 250 long

Fixed Roller

- Load Rating kg (Minimum applies).

Roller Length (mm)	Tube Material				Shaft			
	Dynopipe	Aluminium	Galv.		Spring Loaded		Fixed	
	Ø50mm	Ø50mm	Ø50mm	Ø60mm	Ø12mm	Ø14mm	Ø12mm	Ø14mm
200	30	45	90	85	50	90	55	90
300	30	45	90	85	45	80	55	90
400	28	45	90	85	40	70	55	90
500	16	40	90	85	36	68	55	90
600	12	30	90	85	28	52	55	90
700	5	25	90	85	23	43	55	90
800	3	20	90	85	19	36	55	90
900	2	10	90	85	16	31	55	90
1000	1	6	85	85	15	28	55	90
1100		4	80	85	13	25	55	90
1200		2	65	85	12	22	55	90
1300			45	80	11	20	55	80
1400			35	65	10	18	55	80
1500			25	50	9	17	50	80

- Max. static load 75kg.
- Z9S - Max. static load 30kg.
- Ø60 & Ø89 tubes – Max. 80kg
- Ø10mm shaft – Max. 20kg up to 500 long.
- Ø8mm shaft – Max. 10kg up to 250 long.



A to B, seamlessly.



Auckland 09 320 5535
Canterbury 03 307 0044
Southland 03 216 1440

Freephone 0800 144 044
Email sales@dyno.co.nz
www.dyno.co.nz



It's how businesses get along