

607HD Tube Diameter - 60.3mm

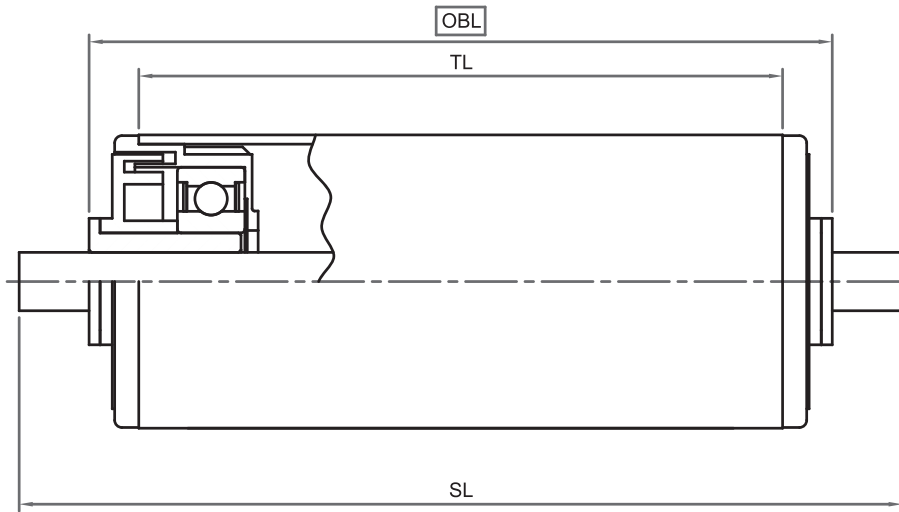

TL = OBL - 20mm (Ø12 & Ø16mm)  
 = OBL - 15.5mm (Ø20mm)

Tube		Bearings		Shaft Materials	
Materials	Standard - 60.3 x 2.3 Galv. steel	Materials	Precision bearing	Materials	Standard - Mild steel
	Standard - 60.3 x 2.3 S/S (50 NB sch. 10)		Black nylon housing		Option - Stainless steel
	Option - 60.3 x 3.6 Galv. steel		Black labyrinth and reducer bush		
			Option - S/S precision bearing (SS)		
				Size	Ø12, Ø16, & Ø20mm
				Type	Standard - Ø12, Ø16 - SP
					Standard - Ø20 - L
					Options - DL, F, FL, FT, L, MT

- Load Rating kg (Minimum applies).

Roller Length (mm)	Tube Material Galv. or S/S	Shaft					
		Spring Loaded			Fixed		
		Ø12mm	Ø16mm	Ø20mm	Ø12mm	Ø16mm	Ø20mm
100	280	250	350	350	300	350	350
200	280	200	350	350	280	350	350
300	280	160	350	350	250	350	350
400	280	120	350	350	250	350	350
600	240	80	280	350	250	350	350
800	140	50	200	350	250	350	350
1000	100	30	160	320	250	350	350
1200	80	20	140	260	250	350	350
1400	60		120	200	250	350	350
1600	40		100	140	250	350	350
1800	20		70	120	250	350	350
2000			50	100	250	350	350

\* Shaded sizes not recommended

- Rated speed 70m/min.
- Max. static load 250kg.
- For central point load, reduce load rating by 1/3.
- Option; For heavy duty, all S/S & plastic roller.