

605HD Tube Diameter - 60.3mm

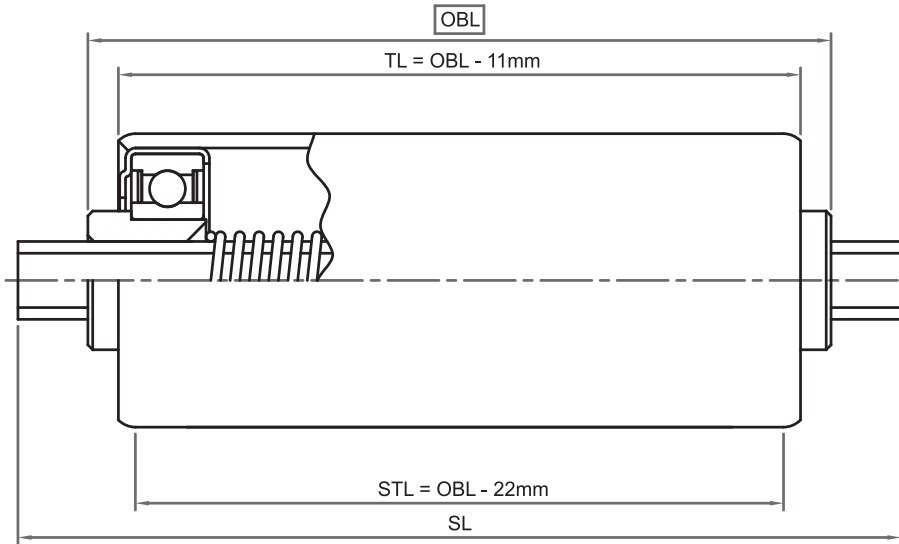

Tube		Bearings		Shaft Materials	
Materials	60.3 x 3.6 Galv. steel	Materials	Precision bearing	Materials	Standard - Mild steel
	60.3 x 3.9 Stainless steel		Steel housing and bush		Option - Stainless steel
			Zinc plated	Size	Standard - 16H
					Option - Ø16mm, Ø19mm
				Type	Standard - SP
					Options - DL, F, FL, FT, L, MT

- Load Rating kg (Minimum applies).

Roller Length (mm)	Tube Material S/S or Galv.	Shaft			
		Spring Loaded		Fixed	
		16H	Ø19mm	16H	Ø19mm
100	400	400	400	400	400
200	400	400	400	400	400
300	400	400	400	400	400
400	400	400	400	400	400
600	300	280	400	400	400
800	250	200	400	400	400
1000	200	160	320	400	400
1200	160	140	260	400	400
1400	120	120	200	400	400
1600	80	100	140	400	400
1800	55	70	120	400	400
2000	40	50	100	400	400

* Shaded sizes not recommended

- Rated speed 70m/min (speed can be increased with decreased load).
- Max. static load 380kg.
- For central point load, reduce load rating by 1/3.

Common uses;

- Heavy in feeds to machines.