

CONVEYOR ROLLERS

605 Tube Diameter - 60.3mm

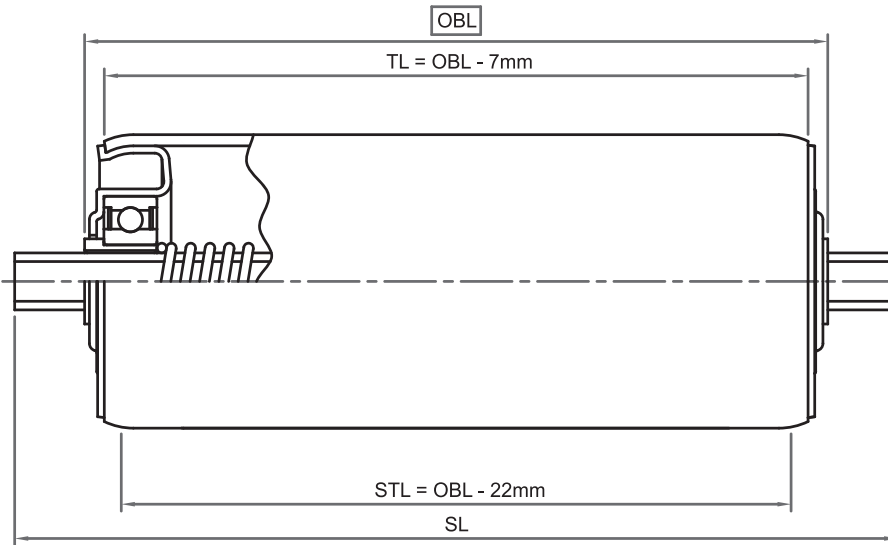

Tube		Bearings		Shaft Materials	
Materials	Standard; 60.3 x 2.3 Galv. steel	Materials	Precision bearing	Materials	Standard - Mild steel
	Option; 60.3 x 3.6 Galv. steel		Steel housing & bush		Option - Stainless steel
			Zinc plated	Size	Standard - 11Hex
					Option - Ø8, Ø10, Ø11, & Ø12mm
				Type	Standard - SP
					Options - DL, F, FL, FT, L, MT

- Load Rating kg (Minimum applies).

Roller Length (mm)	Tube Material Galv.	Shaft				
		Spring Loaded			Fixed	
		Ø8mm	Ø10mm	11H	Ø10mm	11H
100	180	100	180	180	180	180
200	180	80	120	180	160	180
300	180	40	90	160	160	180
400	180	30	80	80	160	180
500	180	20	70	70	160	180
600	180	15	60	65	160	180
700	160	10	50	60	160	180
800	140	5	40	55	160	180
900	100		30	50	160	180
1000	80		20	45	160	180
1100	60		10	40	160	180
1200	50		5	35	160	180

* Shaded sizes not recommended

- Max. speed 70m/min.
- Max. static load 150kg.
- For central point load, reduce load rating by 1/3.

Common uses;

- Gravity rollers where plastic housing is not applicable – eg. high or low temperature