

# SOUTHMACH SPECIAL!



## 30% discount

on all Arhburg Gear Reducers and Motors until  
the 30<sup>th</sup> June 2016 when you quote the code

## "SOUTHMACH"

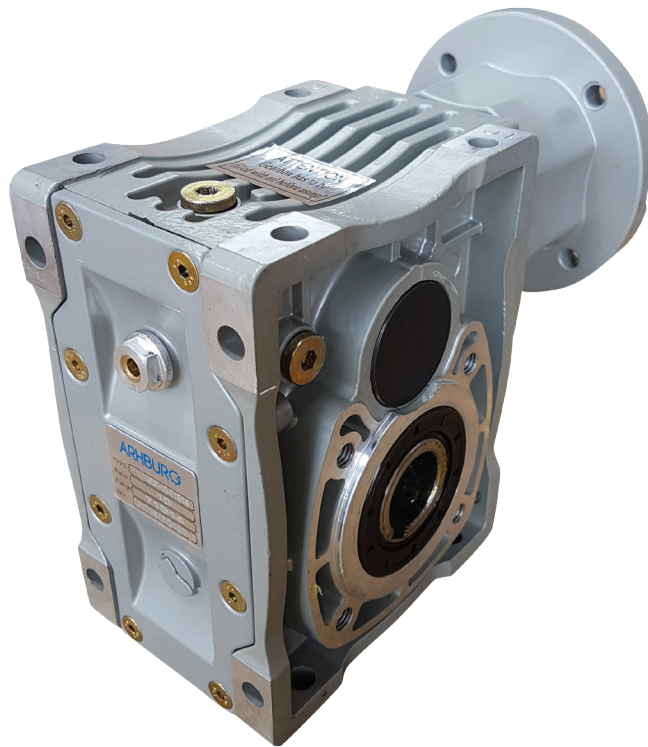

FORGE AHEAD, KEEPING INNOVATION

## Hypoid Gear Reducer

## Hypoid Gear Reducer

Hypoid gears are key components in right-angled gearboxes with high reduction ratios, high efficiency and compact size.

### Features & Benefits

- High efficiency - up to 30% energy savings compared to a worm box
- Low noise
- Low temperature
- Durability - low maintenance costs
- Universal mounting - Interchangeable with most worm gearboxes
- 4 sizes available
  - 1 - WAH 50 max. 130Nm
  - 2 - WAH 63 max. 200Nm
  - 3 - WAH 75 max. 350Nm
  - 4 - WAH 90 max. 500Nm
- All 2 - 3 stage variants in ratio ranges  $i = 7.5$  to  $i = 300$
- Available as separate gearbox or complete geared motor (0.12 kW to 4 kW)
- Lightweight Aluminium frame
- Range of hollow shaft sizes available to order
- Standard viton seals & synthetic lubricant

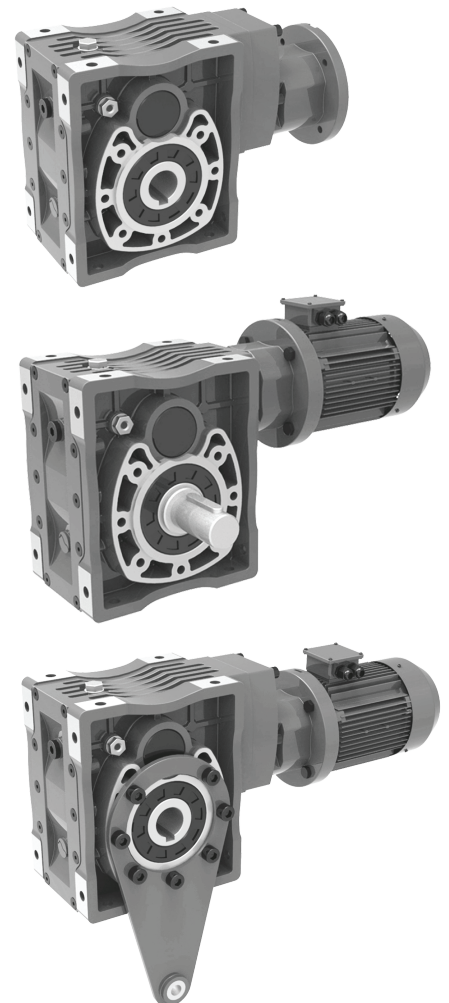

Why waste your energy?

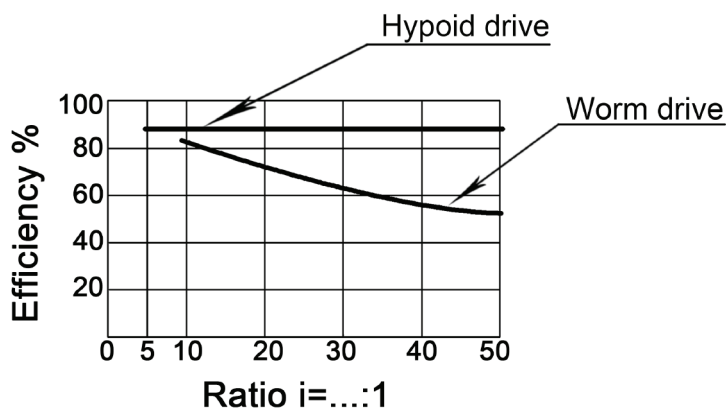

***Make the change from worm drive to hypoid drive today!***